

# Do **YOU** know Jim?

Jim, 34, enjoys his morning coffee. Today he can enjoy that coffee feeling confident that there are many more mornings like this to come.

Sadly, his father wasn't so lucky. His life was cut short by a heart attack when he was only 41. As happens with about one in three heart attacks, it came almost without warning. *Almost*, except a strong family history of **heart disease**.

Unlike his father, Jim and his new health care provider discussed his family history at his first visit to the new practice. Jim's provider learned of the tragedy of Jim's father and that Jim had also lost his grandmother and an uncle to heart attacks when they were in their early 40s. A quick lab test showed that Jim's total cholesterol was 300.

With a new perspective on the importance of that family medical history, Jim was more than willing to make some lifestyle changes: taking a new medication, giving up smoking, and starting a new diet and exercise program. It hasn't been easy, but Jim's not complaining. It is, after all, a really good cup of coffee.

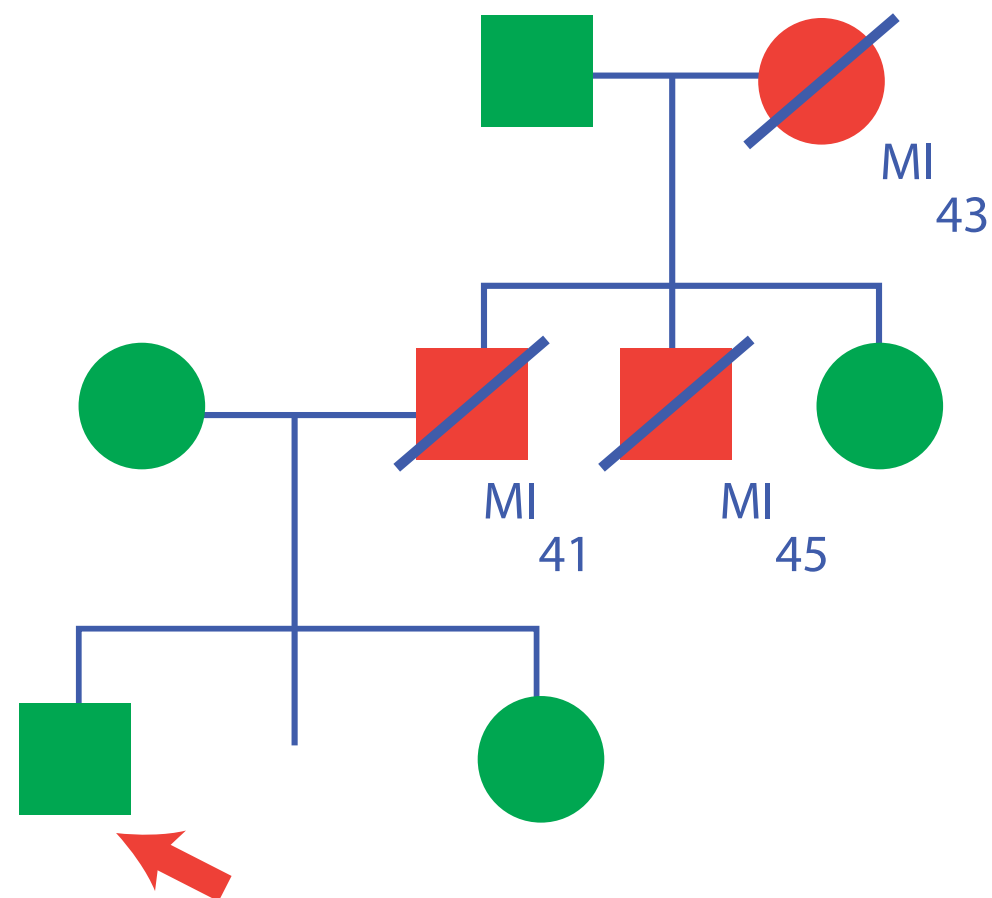

**The next time you see a “Jim,” take the time to obtain a complete family history. It could make the difference of a lifetime.**

The U.S. Surgeon General's **MY FAMILY HEALTH PORTRAIT TOOL** can help your clients gather and organize their family history before visiting your office.  
Direct them to it at [www.surgeongeneral.gov/familyhistory/](http://www.surgeongeneral.gov/familyhistory/)

