

# Do YOU know Maria?

Maria, 38, is a healthy mother of two who likes to jog, doesn't smoke, or drink, watches her diet and has faithfully seen the same primary care provider each year for the last 15 years. But in six months, she'll find that she's at risk for a serious disease.



Five years ago, Maria's sister, then 42, was diagnosed with early stage breast cancer. Fortunately, her cancer was localized, and today she's doing well. Unfortunately, Maria's primary care provider never asked about her family history.

In a few months, Maria will move and begin seeing a new PCP. When he takes a family history, he'll learn about her sister's cancer. He'll also discover that Maria's paternal aunt died at age 48 of ovarian cancer. Maria's new provider will recognize that Maria and her daughters are at risk for **hereditary breast and ovarian cancer** syndrome, which affects about one in 800 people and increases the risk of developing certain cancers at a very early age.

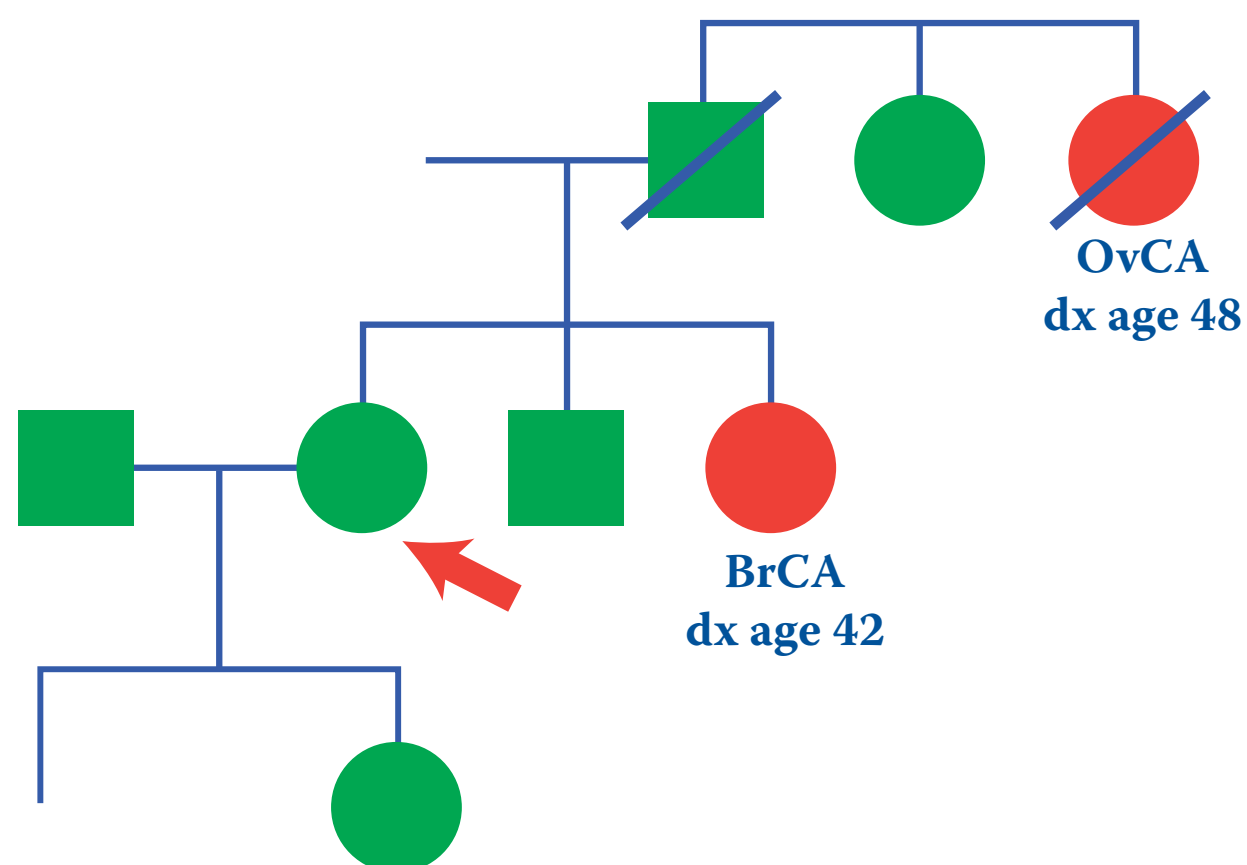

Taking his advice, Maria and her sister will undergo genetic counseling and testing. They'll learn that they carry a change in the BRCA1 gene known to cause hereditary breast and ovarian cancer. Each of them will choose slightly different proven health care options that reduce their risk of potentially fatal disease.

**The next time you see a “Maria,” take the time to obtain a complete family history. You just might save her life and that of her brother, sister, children...**



The U.S. Surgeon General's MY FAMILY HEALTH PORTRAIT TOOL can help your clients gather and organize their family history before visiting your office. Direct them to it at [www.surgeongeneral.gov/familyhistory/](http://www.surgeongeneral.gov/familyhistory/)

